

Milestone Deliverable Sheet – Storyboard Level 1

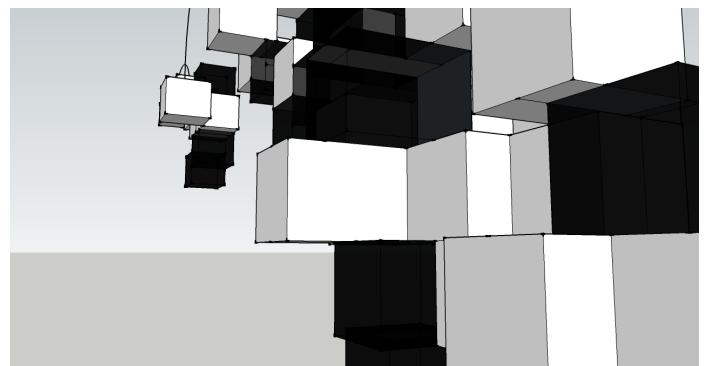

Object: Start at the bottom of the wall and scale the wall upwards then forwards on top of the wall. This task will introduce the player into the fact that the black semitransparent boxes allow the player to go through them and have no collision with.

Character: After realizing that there is no other way to go but up. The character must traverse the wall to push forward.

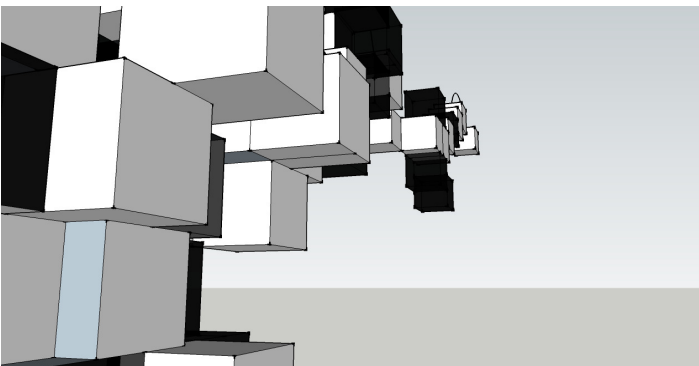
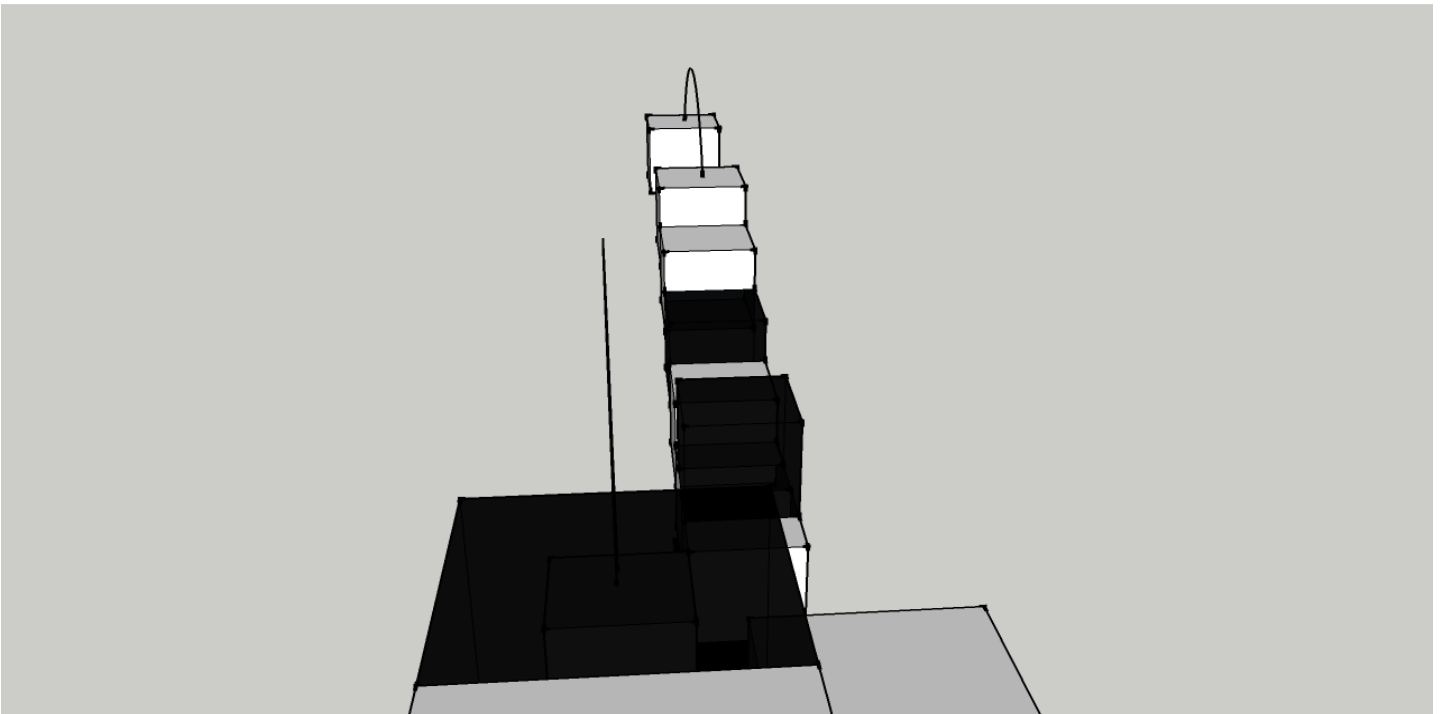
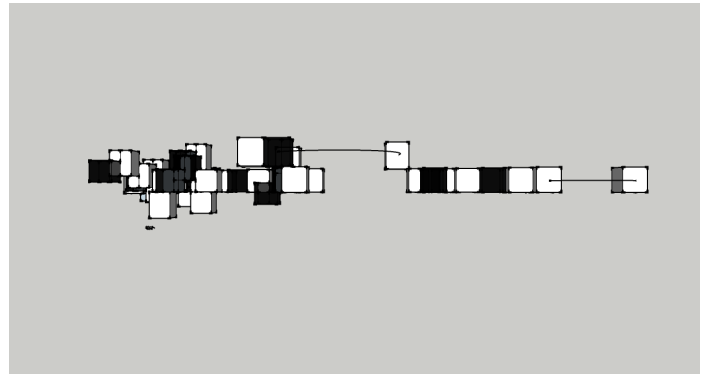
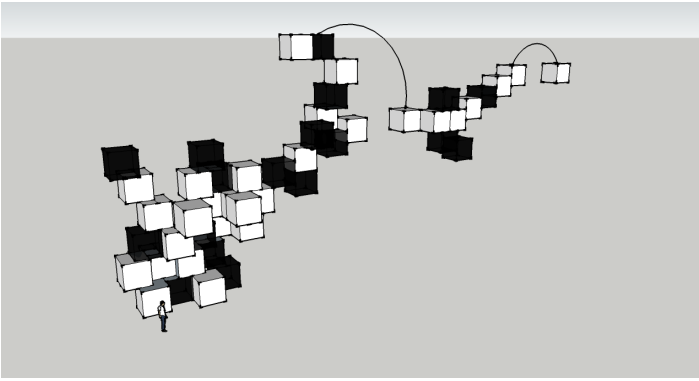